

Measuring Knowledge. Notations, Words, Drawings, Projections, and Numbers

Carlos L. Marcos, Michael Swisher

Abstract

Humans have communicated with each other since they became such. Undoubtedly, the fact that we have developed symbolic systems to communicate should account for such a difference. Moreover, our own evolution in terms of knowledge is inextricably connected to such use.

Different symbolic systems contribute to our knowledge acquisition in different ways. A fundamental divide can be established between verbal languages and graphic ones. Words are easily connected to abstract thinking and a generic approach to reality; we use them to reason and to think. Figurative drawings, on the contrary, appeal to our senses and to visual appearance; they are focused on the material world and try to define relations based on resemblance between tangible reality and modes of its representation, however this controversial term may be. Yet, drawings can also be used to achieve knowledge aided by graphic thinking both through ideation and through representation, depending on the directionality of projections. Most remarkably, architectural drawings based on geometric projections establish an unrivalled and privileged relation with material objects that words or even numbers cannot match. Instead of appealing to the generic—as words—or to the numerically quantifiable—as numbers—, they describe and define a point to point relation with the material existence depicting proportions.

Keywords: notation, drawings, projections, measures, proportions.

Introduction. Knowledge and existence

The methodology in this essay is based on a dialogic enquiry on the nature of knowledge and the different ways in which symbolic systems serve to its nurturing. A distinction is made between allographic and autographic arts, on the one hand, paying special attention to the difference that can be established, within the graphic realm, between the visual arts and architectural drawings beyond their notational nature. Verbal languages are also opposed to graphic languages, while a relation between numbers, measurement and proportions is discussed; between the generic or abstract and the material or concrete as a corollary of the research, thus addressing the proposed theme for this monographic issue. It is necessary to reflect here in certain detail on knowledge and how it is acquired, to ponder the importance of drawing

and measuring epistemologically. Plato's theory of Ideas establishes a duality enormously influential throughout history: a substantial difference between abstract thinking and perception, between reason and the senses; ultimately, between *form* and *matter*. According to Plato knowledge has three different stages: *aesthesis*—perception, sensation—, *doxa*—belief, opinion or judgement— and *episteme*—pure knowledge—. In his *Theaetetus* he reflects on the contingency of material existence and is conscious of the deceitful nature of our perception and our subjective interpretation of it [Plato 1987]. He introduced the notion of *Ideas* detached from matter in his philosophy to ensure dealing with pure realities to reach *episteme*. That is why on this *ideal otherness*—the only *reality*— he imposes to such *Ideas* the attributes of "abso-

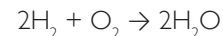

Fig. 1. Willem Claesz Heda. Still Life with Oysters, a Silver Tazza, and Glassware 1635.

lute reality, eternity, immutability, universal and independent from the phenomenological realm" [Grube 1973, p. 20]. This duality ended up duplicating the world while undermining material existence, the world we see and are able to touch [Bueno 1990, p. 38].

Aristotle, critical with regard to Plato, managed to unite the formal and the material realms in his hylomorphic doctrine by introducing the complementary ideas of *power* and act to explain changes [Aristotle 1971, I, VI]. Stepping beyond the pre-Socratic limits of *being* and *non-being* he added an intermediate category, relative non-being or becoming, thus, managing to explain accidental as well as substantial changes. He conceived *substance* as the *real* being composed of two elements: form and matter –*primary matter* [1]–.

Let us comment on an easy example diving now into Physics [2], using, for instance, the combustion of hydrogen to obtain water. The chemical notation for this reaction is as follows:



Two molecules of hydrogen and a molecule of oxygen will produce two molecules of water. This exogenous reaction will imply a substantial change in Aristotelian terms. Two distinct substances, hydrogen and oxygen, are transformed through this chemical reaction into a new substance, qualitatively different from the previous ones. The water is in *act* once the bond between hydrogen and oxygen molecules is established [Zubiri 1989, p. 136]. Any chemist will truly

understand the meaning of that formula quantifying the proportions needed for such transformation as well as the qualitative difference of every element involved.

Whereas *form* is the characterizing element that makes water be what it is, a material element is needed to explain its corporeal existence within the physical realm. The formula of the molecule defines its precise composition but it is not really water as it is not material. In Aristotelian Conceptualism the *real* water is the concrete and specific liquid we may drink in a glass of water, such as the one that tempts to quench the thirst of the observer depicted in Claesz Heda's superb still nature (fig. 1); in Platonic Realism, only the formal existence of the water molecule is the *real*.

Languages and symbolic systems

Humans have managed to develop complex languages to communicate with each other in different ways. They contribute to articulate our judgement and, derivatively, to reach knowledge. According to Goodman [Goodman 1976, p. XI] they are based on symbols [3] in which we embed information in extraordinarily complex and nuanced ways.

A major divide, however, can be distinguished between verbal or textual languages, and figurative graphic languages. The first typically use characters as part of a notational system which, combined, produce words to which we assign a particular meaning; the latter use drawings or images to express and convey a message of visual nature. This establishes a major distinction in the way in which we represent the world that surrounds us, but also the ways in which we acquire knowledge. Such distinction, has had implications within the philosophical debate and knowledge itself, since words are based in abstract or generic thinking. The association between meaning and signifier is fundamental to understand the nature of abstract or generic thinking: common aspects within a given class are used as an operational classification strategy. If we think about it, is it not extraordinary to be able to refer to all the men in mankind with one single word?

This debate on *universals*—species or genders— in opposition to *particulars*—real individuals with material existence—, was held for centuries by philosophers. Nominalism questioned the very existence of universals arguing that words were simply *flatus vocis*, mere sounds, that we operatively use to communicate [Ferrater Mora 1994]. Thus, for nominalist philosophers, universals are neither part of or alien to individu-

als or sensible objects, they are rather elements of language—words— that structure and articulate our judgement.

When we use drawings or images to refer to that same object we base this association in terms of a certain resemblance between the real object and its representation. The closer a portrait of someone is to his visual appearance—with all the proportions and details that constitute his physiognomy—, the more accurate will we say the picture is. This relation, albeit entailing a certain amount of codification, is based on analogy [Deleuze 2008]. Words are *arbitrarily* chosen to stand for a meaning whereas drawings and images have a direct and precise relation with the objects they represent which is not *arbitrary*—at least not in that same way—, for it is based on visual resemblance. Goodman is one of the first authors that has dedicated part of his inquiries to suggest the cognitive dimension of art [Allepuz 2016, p. 790], analysing it beyond its expressive or aesthetic attributes. He has thoroughly studied the relation of resemblance or similitude that is specific to graphic languages within symbolic systems. Although he argues that “plainly, resemblance in any degree is no sufficient condition for representation” [Goodman 1976, p. 4] his reasoning seems to be too conditioned by the aim of his investigation on symbolic systems. Of course, part of the problem appears with the difficult and problematic term of *representation*, and a series of other considerations around it such as imitation, perspective, realism, description and depiction. Summarizing, Goodman suggests that representation transcends the mirroring of reality subsuming it “with description under denotation” [Goodman 1976, p. 43]. In other words, it could be said that a drawing or a painting—a figurative one, we must add— denotes the object or motive it refers to while it describes it in terms of resemblance to its visual appearance.

Goodman's theory of symbol systems also addresses the idea of notation, something very relevant for our research. Accordingly, there are allographic and autographic arts. The first use notations that allow those who use them to convey to third parties their creative endeavours, such as it happens with scores in music or with plans in architecture. The second are considered autographic “if and only if the distinction between original and forgery of it is significant” [Goodman 1976, p. 113], as is the case of painting. Goodman heavily relies on the role of copies and originals, on the one side, and on the relation between the referent and its representation. Some disciplines use different notational systems in order to effectively denote or refer to the reality symboli-

Fig. 2. Three Connected benzene rings (noncontact atomic force microscope). Lawrence Berkeley Lab. University of California at Berkeley.

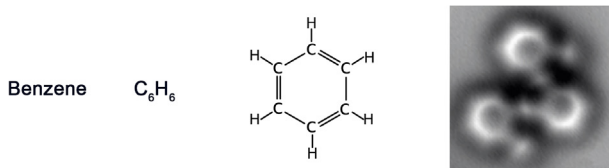

cally represented through them. For instance, we can use four very different ways to refer, notate, diagram or even graphically represent benzene (fig. 2).

The word 'benzene' stands in English for "a clear liquid obtained from petroleum and coal tar, used in making plastics and many chemical products", according to the Oxford dictionary. If we have previously seen and smelled benzene, and know English, we understand what the word refers to but have no clue in relation to its chemical composition. The condensed chemical formula adds a layer of quantitative and partially qualitative information stating that it is composed by six atoms of carbon and six of hydrogen. Of course, we could only understand its meaning in the context of chemistry provided we are aware that 'C' stands for carbon, 'H' for hydrogen and the '6' subscripts stand for the number of atoms of each element. The same benzene molecule notated using the Lewis structure or chemical notation diagram still adds an extra layer of relevant information: it effectively gives the same quantitative information of the condensed chemical formula, but unlike it, it is also a diagrammatic attempt to graphically display the bonding between atoms and the lone pair of electrons that may exist. Lewis notation structure manages to show in a very synthetic way an enormous amount of relevant information. These three different notations for benzene convey different kinds of information. However, the first two, are strictly 'textual' whereas the third also includes some graphical information however symbolic and non-figurative as it may be. It is because of its diagrammatic nature that it is capable of adding relevant information regarding its formal structure. It is of course an idealized denotation of the benzene molecule, not a real representation of its essence, but this graphical envisioning of information [Tufté 1990] certainly accounts for the divide between verbal and graphic languages and the information they bear. There is yet a fourth truly graphical representation of the benzene molecule in figure 2. In fact, it corresponds to an image of three con-

nected benzene rings revealing the positions of individual atoms, achieved through a noncontact atomic force microscope. Whereas the previous three are different notations to denote benzene thanks to symbolic systems, the fourth is actually a microscope image of three real *material*-bonded benzene rings. And this is indeed an extraordinary difference in metaphysical terms: the word 'benzene', the condensed formula, and the benzene Lewis structure are abstract ways in which we refer to benzene as a *form*, whereas the microscope image is, in fact, a true representation of a particular reality with true *material* existence of three benzene molecules.

Allographic and autographic arts. Music, drawings and technical drawings

What is most striking with regard to Goodman's approach –being a philosopher– is the fact that no attention is given to the major difference between verbal languages and notational systems, on the one hand, and graphic languages, on the other: It is the unmatched potential of *technical drawing* to refer to the material world that which makes of it so extraordinarily effective in the representation of the architecture or engineering. And it is also the reason for another substantial criticism to be made to Goodman's theory: musical scores and architectural plans, however allographic as it may be their nature, radically differ in the lack of musical scores to relate to the sound they stand for in comparison to the ability for plans to precisely relate to architecture. In the case of music, once the composer writes the score he has finished his creative work. Nonetheless, the music is *not* the score: it needs to be performed by others –or, eventually, by the composer himself, that is unimportant– to produce *sound* and *become* real music. In the case of architecture, Carpo suggests the origins of this *allographic* nature in Alberti's *lineamenta* and his redefinition of the role of architects as designers rather than builders. It was precisely at that time when architects abandoned the medieval tradition of master builders directly involved in the construction of the cathedrals –which could be considered *autographic*– and commenced their designing tradition *scripting* their art into architectural plans for others to materialise their execution [Carpo 2011, p. 16]. Allographic arts imply the reliance of the creative author on notational systems that allow others –performers or makers–, to materialise his work, be it a symphony or a cathedral. Yet, architectural

Fig. 3. Music score and tablature of Bach's Sarabande of Lute Suite no. 1.



representation clearly differs from music in as much as it belongs to the graphic realm, and, furthermore, it is based on projections, which has further significant implications.

Let us choose an object, a lute for instance. If we think of it in the context of languages such as English, Italian or Spanish we could refer to it with the words 'lute', 'liuto' or 'laúd', respectively. The fact that these different words all refer to a same object accounts for the arbitrariness of the sign.

The music that can be played on the lute can be written in a musical score. The very effective but abstract and complex notational system of the music scores led early lutenists to devise an alternative, more intuitive and instrument-oriented type of scores called *tablatures* that are still currently used among amateur lute and guitar players (fig. 3). Musical scores allow for further information and nuances but tablatures are more practical as instead of the pentagram there are six lines that stand for each of the six strings or courses—doubled strings in lutes—, the numbers correspond to the fret in the fingerboard, and normally the stems and flags above the upper line stand for the duration of the note. The score is what the composer writes for the interpreter to play the music but there is no clue in this pure notational system to the sound we will be able to listen to unless we are proficient in reading music. Note how those two very different musical notational systems in Bach's Sarabande of Lute Suite no. 1 are scores for the same music.

Someone with no draughtsmanship abilities can attempt to draw the lute that he directs his gaze at. He will eventually produce a figurative drawing that will somewhat resemble the visual appearance of the lute; most likely failing to precisely draw the foreshortenings produced by perspective. Accordingly, the drawing will look disproportionate and

naïve; yet, we will most likely identify that it refers to the lute. Even a well-trained draughtsman will not be able to completely avoid small distortions and disproportions in as much as he will be attempting to reduce a three-dimensional reality into a two-dimensional drawing. His task will not include to precisely measure but will rely on his ability to reproduce a drawing as accurate as possible to the visual appearance of the lute cast on his retina. These drawings, regardless of their naivety or realism, will denote the lute both draughtsmen see. If we observe the many portraits of the king Philip IV that Velázquez was commissioned to paint we will notice the great resemblance between them, even the aging of the monarch throughout his lifetime. This certainly accounts for Velázquez's mastery but, presumably, their fidelity to the referent is not photographic. While Picasso's was 'academically' learning his trade, he copied some of Velázquez's work (fig. 4); a purposely *forgery* and a good example of Goodman's argument with regard to the necessary autographic nature of painting as "even the most exact duplication of it does not thereby count as genuine" [Goodman 1976, p. 113]. Of course, his endeavour in this case was not as challenging as that of Velázquez: he only had to transpose from two dimensions into two dimensions. To a certain extent, his copy of Velázquez's portrait of Philip IV is a reinterpretation of Velázquez's painting—its true referent—but the king would only be indirectly referred to despite the shocking resemblance between the men depicted in both paintings. Nevertheless, these two paintings lack the relation of allographic duplication between the plan—the design—and built architecture—the construction—that Carpo [Carpo 2011, p. 22] refers to with regard to Alberti's building by design: they would be autographic forms of art in Goodman's theory.

The lute in the famous Dürer's engraving did probably exist as a referent (fig. 5). Thanks to his drawing machine, Dürer was able to produce a literal projection on a paper of its geometry. Such drawing is an accurate geometric projection of the lute—that concrete lute and no other—. Although the necessary foreshortening implicit in the chosen system of projection—central projection or perspective—does not allow to measure the true dimensions of the lute, it does establish a point to point relation between reality and its representation: a pure analogy.

This is of major importance and it is also something that Goodman fails to discuss: autographic arts establish a connection between the referent and its representation, between the particular material referent and its physical rep-

Fig. 4. Velázquez, *King Philip IV*, 1653-1655 (left). Picasso (copy of Velázquez's painting), 1897 (right).

Fig. 5. Albrecht Dürer, *The Draughtsman and the Lute*, 1525.

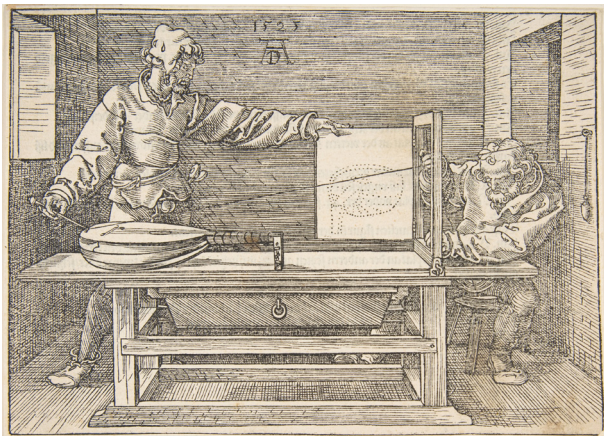

resentation. In the case of precise geometric projections characteristic of architectural or technical drawings, that relation is far from being only notational or merely graphic, it is much more than any of the two. Invisible projection lines relate drawings and images to things [Evans 1989, p. 19] establishing an intimate connection between the material world and its representation much more precise than the best verbal description ever.

Alberti in his *De Re Aedificatoria* warns us about the deceiving nature of perspective which he recommends for the painter as his interest is focused on the representation of visual appearance. He adds that architects should only use parallel projections to ensure that 'determined and rational dimensions' in their projects may be accurately conveyed to third parties and, thus, properly serve to define their architectural designs [Alberti 1991, p. 95]. Only that which can be measured and precisely represented can be built by others: that is the reason why technical drawings have been so important to architects or engineers for centuries, and their role so influential in the diffusion of architectural theory during the Renaissance [Carpo 2001]. In other words, plans are *translated into buildings* [Evans 1997]. They connect the material world in different ways; it is thanks to plans that we can anticipate architecture or graphically represent it, depending on the direction of the projection. While the plans architects draw before the construction of the building anticipate architecture itself, reversely, built architecture can be also cast back onto survey plans [Evans 1989, p. 19]: both representations are virtually architecture or rather, *potential* architecture, whereas built architecture is *actual* architecture in Aristotelian terms. Note that the virtual nature of architecture in architectural drawings affects projects or survey plans alike. This relation is so intimate that it lead Boullée, and others after him (Allepuz, Marcos 2017), to sustain that architectural drawings, being the cause of built architecture –its effect– should be considered architecture as much as the building is if not more.

Quantity, numbers, measures

Numbers are also codifications or notations which stand for the countable. A new plane of abstraction is needed to understand their nature because unlike words, images or drawings, they do not refer to objects themselves, but to the quantifiable that can be inferred from them. The evolution of numbers throughout the history of mathematics is intimately connected to the need to count in different

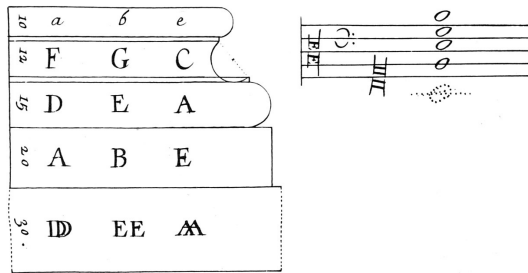

Fig. 8. François Blondel. Harmonically proportioned Attic base with its corresponding chord, *Cours d'Architecture*, 1683.

of capitals in San Cugat's monastery cloister and the Gregorian chants of San Cucufate's martyrdom, the saint to which the building is devoted (Cabezoz, Rossi 2017). St. Augustin thought that "music and architecture are sister arts, both based on number; which ranks as the source of all aesthetic perfection" [Kruft 1994, p. 36]. This tradition extended its influence over centuries, reaching very literal attempts to achieve such perfection, for example, in the case of Blondel's attic base design (fig. 8), as Evans [Evans 2000, p. 242] has accounted for. Generally speaking, the analogy was established between the musical intervals –the basis of chords and, by extension, of harmony– although it could also be established with regard to rhythm.

Wittkower [Wittkower 1953] also explained how perspective could also include the harmonic series (1, 1/2, 1/3, 1/4...) if looking in the right direction from a precise position in Brunelleschi's Santo Spirito and San Lorenzo churches. Something that Evans carefully drew later on (fig. 9), showing these interesting relations in the perspective and others in section [Evans 2000, p. 252]. Wittkower [Wittkower 1953, p. 291] argued that when architects abandoned Brunelleschi's idea of homogeneous spatial articulation "it was a signal for the break-up of the Renaissance unity between objective proportions and the subjective optical appearance".

These measurable ratios and proportions certainly connect architecture to music through the harmonic scale but, above all, they are also related with perspective and, indirectly with painting and architectural representation. Nevertheless, it is interesting to point out how musical

harmony can be related to orthogonal projections and architecture, whereas rhythmic proportions or mensuration –as it is called in music– is to be found in perspective drawing, a certainly intriguing quirk.

The sought for order in architecture as a source of beauty not only was inspired in music and the quantifiable. Additionally, Renaissance's humanistic approach found in the human figure another inspiration for proportions and beauty supported by Vitruvius himself. The parallel he established between proportions of the temples and the perfection of the human figure to be inscribed within a circle and a square led to several graphic interpretations of what was to become one of Renaissance most memorable icons –Leonardo's Vitruvius man– who was to be reinterpreted by others differently.

Comparing Leonardo's drawing with others of his contemporaries, it can be observed that even in the representation of the human figure a more pictorial and visual approach, such as the one by Francesco di Giorgio, can be perceived, in comparison to a more scientific and frontal orthogonal projection in the versions by Cesare Cesariano and Leonardo himself (fig. 10). This dual projective approach based on parallel or central projections constitute two complementary systems characteristic of graphic representation: one shows what things really are and the true measures and proportions whereas the second is focused on visual appearance and how we perceive reality [Arnheim 2005, pp. 126, 127].

The fact that those alleged beautiful proportions influenced the language of the discipline itself is certainly surprising if we consider the extent to which beauty derived from proportions is culturally relative. It is easy, for instance, to compare and gauge the very different beauty canons to be observed in painting in a simple time span of no more than two-hundred years. The mythological theme of the Three Graces –daughters of Zeus with Eurynome– has been depicted relentlessly. If we compare the versions of the topic by Botticelli, Raphael or Rubens it is easy to guess that beauty is voluble or at least, our consideration of it (fig. 11). It is, therefore, logical that architects tried for centuries to set a fixed canon of architectural beauty that could ensure the righteousness of their designs. It was the reference to the classical repertoire and its order-based language that Roman architecture had adopted from the Greeks what proved to be an unsurmountable aesthetic peak. The *autoritas* granted to Vitruvius theory only became to be questioned once the printing press allowed to include graphic interpretations of his text. Words are incapable of measuring drawings, on the other

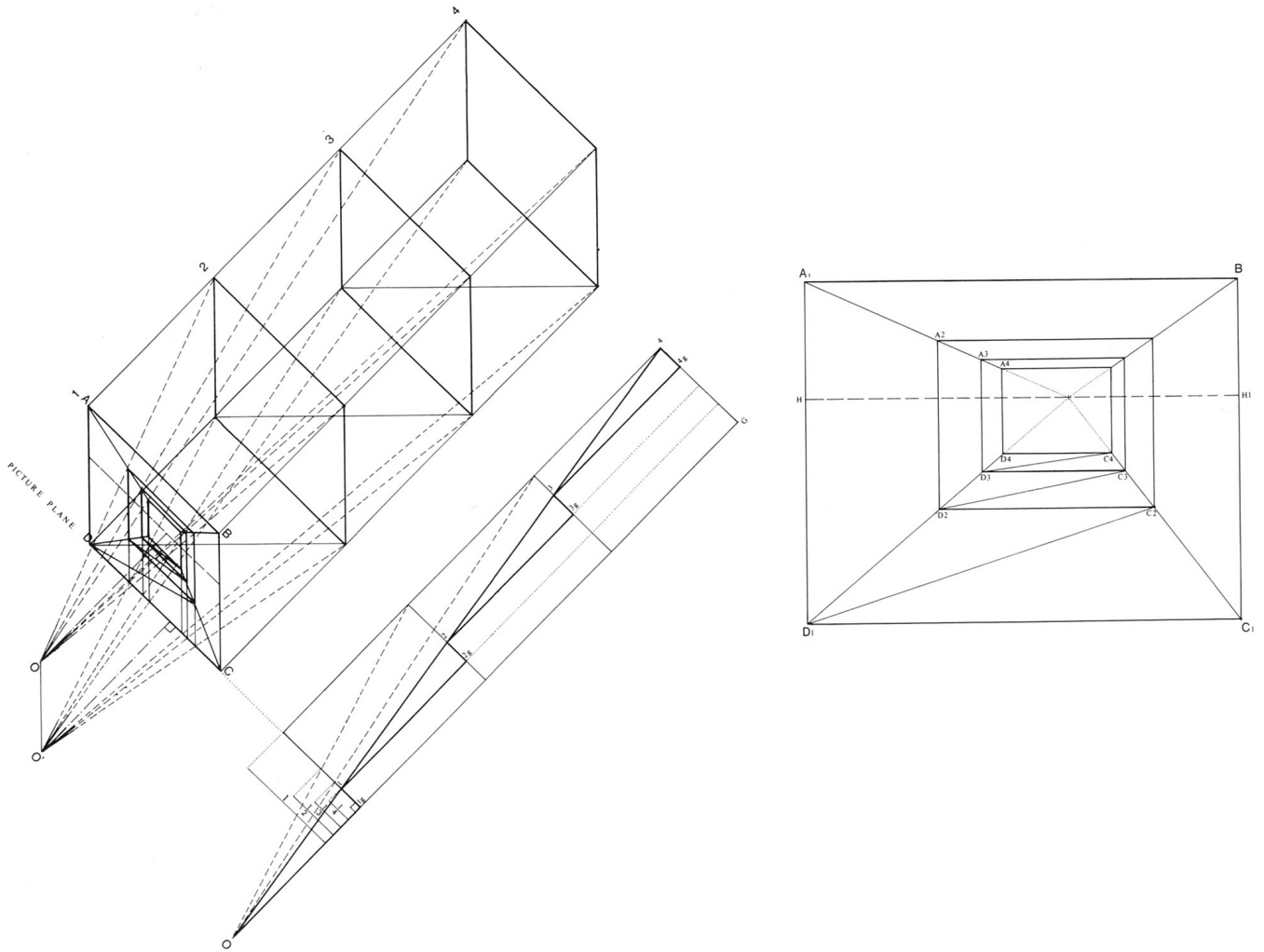
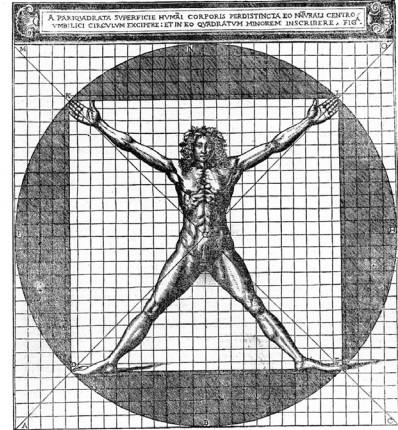
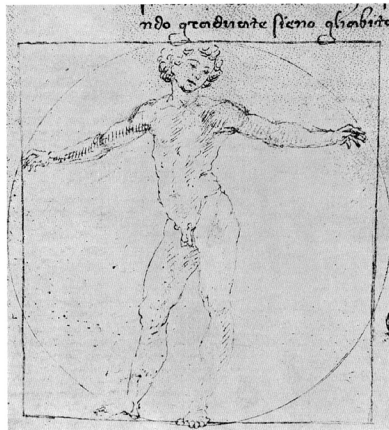
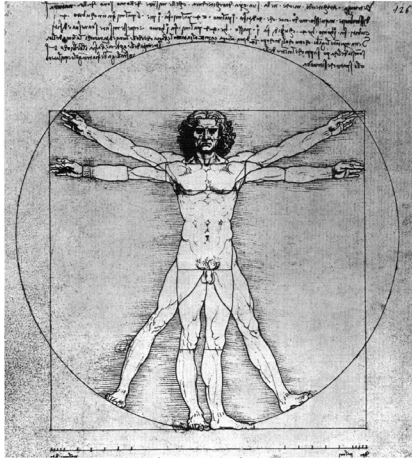

Fig. 9. Harmonic ratios in perspective (1, 1/2, 1/3, 1/4); [Evans 2000].

Fig. 10. Vitruvian figure. Leonardo da Vinci (left), Francesco di Giorgio (centre), Cesare Cesariano (right).

Fig. 11. Three graces. Botticelli, c. 1480 (left; detail), Raphael of Sanzio, c. 1504 (centre), Peter Paul Rubens, 1630-1635 (right).



hand, are. The moment different orders started to be drawn it became obvious their proportions differed. In fact, built classic architecture did not always use the very same precise proportions but rather, a range of them for every order.

This debate became vivid during the eighteenth century in the so-called '*querelle des anciens et des modernes*', whose echoes transcended the *l'Académie royale d'architecture* [Gerbino 2010]. Blondel defended the archetypical use of the long-established classical orders because of their accredited sense of proportion and considered them a natural source of beauty, uncritically following Vitruvius *dictum*. Perrault, arguably objected that the proportions were not an absolute value of beauty but rather something we had grown accustomed to see and, therefore, learned to esteem as beautiful through experience.

Although it is certain that beauty is contextually or culturally relative it is also true that it is dependent on proportions. There is no absolute mensurable numerical value or ratio for these proportions. Although Alberti writes with regard to beauty as "a form of sympathy amid consonance of the parts within a body, according to definite number, outline, and position, as dictated by *concinnitas*, the absolute and fundamental rule in Nature" he does not give a fixed value for it. Much on the contrary, he uses a synthetic judgement in Kantian terms so that the definition of this harmonic perfect beauty is relatively open: "For every body consists entirely of parts that are fixed and individual; if these are removed, enlarged, reduced, or transferred somewhere inappropriate, the very composition will be spoiled that gives the body its seemingly appearance." The elevation of Palladio's *Redentore* drawn by Scamozzi is eloquent to this regard (fig. 12).

Conclusions

Symbolic systems contribute to our acquisition of knowledge in different ways. Verbal languages fail to accurately represent sensible objects whereas architectural drawings define a precise relation between material reality and its representation. This basic divide establishes an effective difference in the way technical drawings and knowledge should be considered. They are notational systems that possess an unmatched accuracy regarding their referents. Unlike music, their allographic nature surpasses the natural allographic limitations of musical scores as they establish a point-to-point relation based on analogy and projections. Accordingly, they can precisely depict the quantifiable and its proportions.

Fig. 12.A. Palladio, *Il Redentore*, Venice, 1576-1592. Drawing by O. Bertotti Scamozzi.



Notes

[1] Primary matter is the material continuum of the real world: the basic bricks of existence.

[2] Even though philosophers naturally establish a distinction between Physics and Metaphysics it is precisely the point that we attempt to make here: the difference between the concrete specificity based on particulars that characterise the physical world and the abstract and generic one, based on universals or the formal approach constituent of Metaphysics –“beyond physics” and dealing with existence–. This has a very relevant relation with regard to symbolic systems and representation; most spe-

cifically with respect to the very singular relation between architectural representation based on projections and the material world.

[3] Goodman uses the term 'symbol' including in it: "letters, words, texts, pictures, diagrams, maps, models and more", but has no further connotation in terms of what could be related to symbolism [Goodman, op. Cit, *ibidem*].

[4] For instance, given two measures, a and b, a/b is the ratio between them whereas $a/b=(a+b)/a$ is the equivalence that defines the so-called divine proportion.

Authors

Carlos L. Marcos, Department of Graphic Expression and Cartography, University of Alicante, carlos.marcos@ua.es
Michael Swisher, School of Architecture, The University of North Carolina at Charlotte, mtswishe@unc.edu

Reference List

- Alberti, L.B. (1991). *De Re Aedificatoria*. Madrid: Akal.
- Allepez Pedreño, Á. (2016). *Architectural Drawings and Symbolic Systems. Implications of Goodman's and Gardner's Theoretical Approaches in Project Zero*. In E. Castaño Perea, E. Echeverría Valiente (eds.). *Architectural Draughtsmanship. From Analog to Digital Narratives*, Proceedings of EGA 2016, Congreso Internacional de Expresión Gráfica Arquitectónica, pp. 787-798. Cham: Springer.
- Allepez Pedreño, Á.; Marcos, C.L. (2019). Dibujo frente a construcción: dos medios para representar la arquitectura. In Martínez-Medina, Andrés (Ed.), *Tiempos de la arquitectura*, Madrid: Munilla-Lería, pp. 37-58.
- Arnheim, R. (2005). *Arte y percepción visual*. Madrid: Ed. Alianza Forma.
- Aristotle. (1971). *Metaphysics*. Oxford: Clarendon Press.
- Bueno, G. (1990). *Materia*. Oviedo: Ed. Pentalfa.
- Cabezos Bernal, P.M., Rossi, A. (2017). Virtual musealization techniques. The capitals of the monastery of San Cugat. In *Revista EGA*, Vol. 22, No. 29, pp. 48-57.
- Carpo, M. (2001). *Architecture in the age of printing*. Cambridge (Mass.): The MIT Press.
- Carpo M. (2011). *The Alphabet and the Algorithm*. Cambridge (Mass.): The MIT Press.
- Chías Navarro, P. (2006). De la imagen y el sonido. In *EGA Expresión Gráfica Arquitectónica*, n. 11, pp. 60-75.
- Deleuze, G. (2008). *Pintura. El concepto de diagrama*. Buenos Aires: Ed. Cactus.
- Descartes, R. (1995). *Los principios de la filosofía*. Madrid: Alianza Editorial.
- Evans, R. (1989). Architectural Projection. In E. Blau, E. Kaufman (Eds.). *Architecture and its image: four centuries of architectural representation*. Montreal: Canadian Centre for Architecture, pp. 18-35.
- Evans, R. (1997). Translations from drawing to building, in *Translations from drawing to building and Other Essays*. Cambridge (Mass.): The MIT Press.
- Evans, R. (2000). *The Projective Cast. Architecture and Its Three Geometries*. Cambridge (Mass.): The MIT Press.
- Ferrater Mora, J. (1994). *Diccionario de Filosofía*. Barcelona: Ariel.
- García, M. (2009). Prologue for a history, theory and future of patterns of architecture and spatial design. In *Architectural Design*, Vol. 76, No. 6, pp. 6-17.
- Gerbino, A. (2010). *François Blondel: Architecture, Erudition, and the Scientific Revolution. The Classical Tradition in Architecture*. New York: Routledge.
- Goodman, N. (1976). *Languages of Art. An Approach to a Theory of the Symbols*. Cambridge (Mass): Hackett Publishing.
- Grube, G.M.A. (1973). *El pensamiento de Plantón*. Madrid: Ed. Gredos.
- Hofstadter, D.R. (1982). Metamagical Themes. The music of Frederic Chopin: startling aural patterns that also startle the eye. In *Scientific American*, Vol. 246, No. 4, pp. 16-31.
- Kruft, H.W. (1994). *A history of architectural theory: from Vitruvius to the present*. New York: Princeton Architectural Press.
- Plato. (1987). *Theatetus*. London: Penguin Classics.
- Tufte, E.R. (1990). *Envisioning information*. Cheshire: Graphics Press.
- Wittkower, R. (1988). *Architecture in the Age of Humanism*. London: Academy editions.
- Wittkower, R. (1953). Brunelleschi and 'Proportion in Perspective'. In *Journal of the Warburg and Courtauld Institutes*, Vol. 16, No. 3-4, pp. 275-291.
- Zubiri, X. (1989). *Estructura dinámica de la realidad*. Madrid: Alianza Editorial.